

WARRANTY. The F&F products are covered by a warranty of the 24 months from the date of purchase. Effective only with proof of purchase. Contact your dealer directly with us. More information how to make a complaint can be found on the website: www.fif.com.pl/reklamacje



Do not dispose of this device to a garbage bin with other unsorted waste! In accordance with the Waste Electrical and Electronic Equipment Act any household electro-waste can be turned in free of charge and in any quantity to a collection point established for this purpose, as well as to the store in the event of purchasing new equipment (as per the old for new rule, regardless of brand). Electro-waste thrown in the garbage bin or abandoned in the bosom of nature pose a threat to the environment and human health.

PURPOSE

STR-4P controller is designed to control roller blinds (up-down) or other objects (e.g. gates) that are driven with DC electric motor supplied by 12V or 24V with momentary switch (eg. bell).

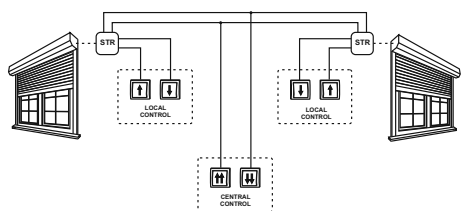

FUNCTIONING

The controller can operate as a stand-alone device (for opening/closing of a single roller blind), but it is also possible to combine controllers into groups to control multiple roller blinds. Roller blind motor starts after momentary passing of the N signal to one of the control inputs. The motor activates for the user-programmed time that allows to fully lift or lower the roller blind. Controller power is indicated by the green U LED light. Motor operation and direction of roller blinds movement is indicated by the corresponding red ↓ or ↑ LED. Roller blind can be stopped on the user-selected level (incomplete opening or closing of the roller blind).

CONTROL

Controller control inputs are divided into two groups: local control and central control.

Local control

Depending on how you connect the controller, it can operate in one or two local keys mode.

TWO LOCAL KEYS

Each direction of movement has its own local key. Short press (<0.5s) switches on the roller blind to move in a given direction for the programmed period of time. Pressing the key when the roller blind is already in motion causes the roller blind to stop. Long press (>0.5 s) switches on the roller blind to move in a given direction for as long as the key is pressed (this allows for example to adjust the tilt of slats).

ONE LOCAL KEY

Local control input Down is connected permanently to the N line. Local control input Up is connected to a key that alternately switches the roller blind to move up or down. Short press (<0,5 s) switches on the blind for a programmed time. Pressing the key when the roller blind is already in motion causes the roller blind to stop. Long press (> 0,5 s) switches on the roller blind for as long as the key is pressed. Each time you press the key the roller blind will move in the direction opposite to the previous one.

Note!

Memory of direction applies both to local and central control. For example, if the controller carries out a Central – Up command, then the next press of a local key will move the roller blind down.

Note!

Memory of direction is not retained after a power failure.

Central control

The controller always works with two central control inputs. Central control allows the roller blinds to move only in the desired direction. Roller blind will stop only after a preset time or by pressing any of the local control keys. If during the execution of one center control command another one is issued with the instruction to move in the opposite direction, the roller blind will stop at first and after 1,5 s will then start to move in the opposite direction. Time of roller blind activation can be randomly delayed in the control center (up to 1 s) to minimize the current surge in the grid in case of simultaneous activation of multiple controllers.

Note!

Central key - Down can also close and lock the roller blind in the closed position. If the **Central key - Down** key is pressed and left in the ON position, the controller will close the roller blind and will not allow for its opening until the **Central key - Down** is released (other inputs will then be locked). This function allows you to lock the roller blinds e.g. when the alarm is armed or when the rainfall (if the additional STR-R rain sensor is used) or too strong wind (if the additional STR-W wind sensor is used) is detected.

INSTALLATION

1. Disconnect the power supply.
2. Mount the controller on the rail in the distribution box.
3. Connect the controller accordingly to the selected scheme of operation.
4. Switch on the power supply.
5. Program the time of lifting/lowering the roller blind.

SCHEDULING TIME OF ACTIVATION

Time of activation can be programmed upon the assumed time of roller blind operation or by activating the roller blind for the test run.

Scheduling for the specified time

1. Press and hold (for approx. 4 s) the PROG key until the green U LED will begin to flash slowly. The controller is now ready for programming.
2. Short press PROG key - the controller starts to measure out the activation time, which is indicated by rapid flashing of U LEDs.
3. After the time has been measured out, press the PROG key again. The controller will save the elapsed time in non-volatile memory and then exit the programming mode, which is indicated by the constant U LED light.

Test run

1. Place the blind in the outmost top or bottom position.
2. Press and hold (for approx. 4 s) the PROG key until the green U LED will begin to flash slowly. The controller is now ready for programming.
3. Short press the local control Up or Down key (in the opposite direction to the current position of the roller blind). The controller starts the motor and begins to measure out the time.
4. After the time has been measured out, press any of the local control keys. The roller blind motor will stop and the controller will save the elapsed time in non-volatile memory and then exit the programming mode.

NOTE!

1. If during the first 30 seconds of the learning mode (slow flashing of U LED) the time measuring will not start (the PROG key is pressed or the roller blind is activated from the local control input), the controller will exit the learning mode.
2. The controller is designed to measure time span shorter than 15 min. Attempting to set the controller for longer span will result in exit from the learning mode.
3. The controller learning mode can be started only when the roller blind motor is turned off.

Operation with factory settings (activation time set to 30 seconds) is indicated in standby mode by short (0.1 s) blinking of U LED repeated every 4 s.

DESCRIPTION OF INPUTS/OUTPUTS

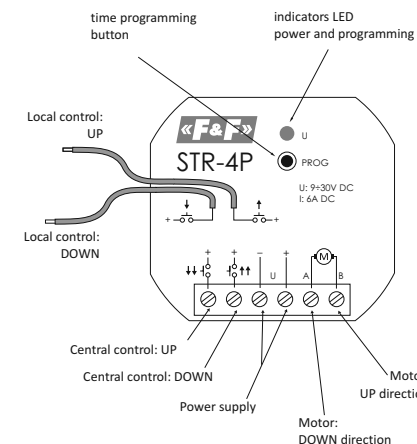

TECHNICAL DATA

power input	12/24 V DC
max. load	6 A
power consumption	
stand by	<0.05 W
on	<0.6 W
control	8÷30 V DC
activation time (programmed)	from 1 s to 15 min.
working temperature (without vapor condensation)	-15÷50°C
indicators	
power and programming	green LED
terminal	screw terminal 2.5mm ²
tightening torque	0.4 Nm
terminal local control	2×DY 1 mm ² / l=10 mm
dimensions	43×48×20 mm
mounting	to under plaster box Ø60 mm
protection grade	IP20

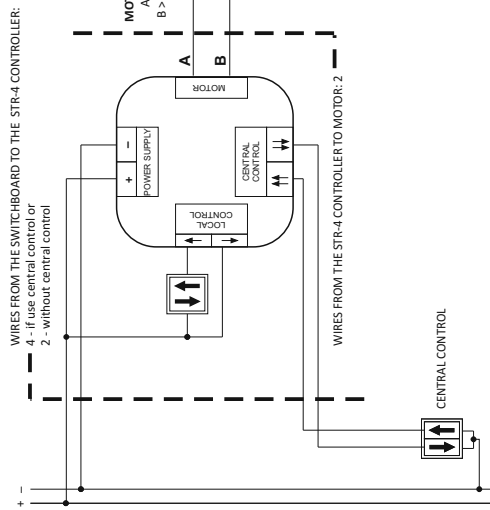

Example of wiring – one local key mode

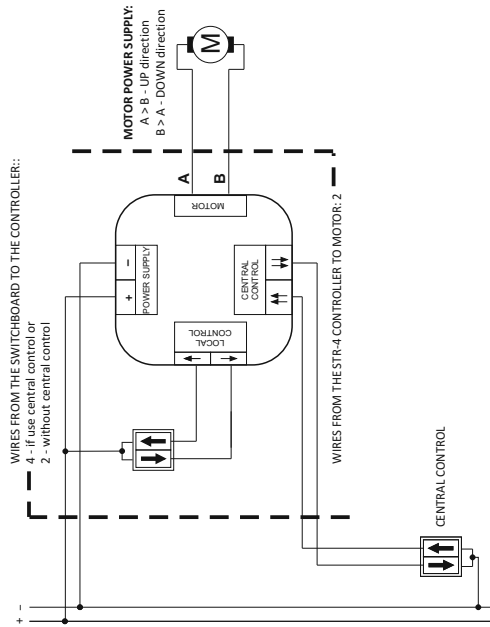

Example of wiring – two local keys mode

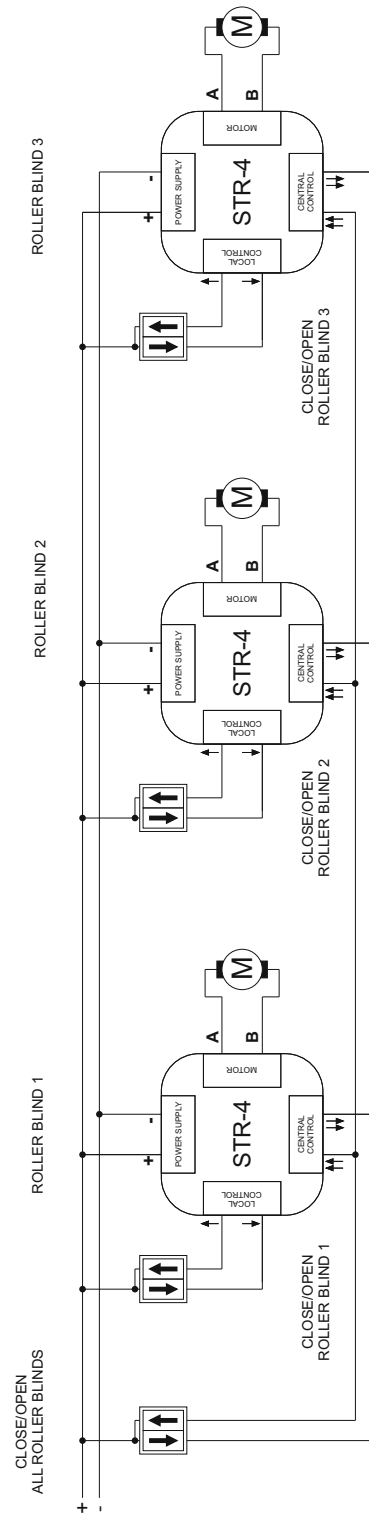

Example of group control

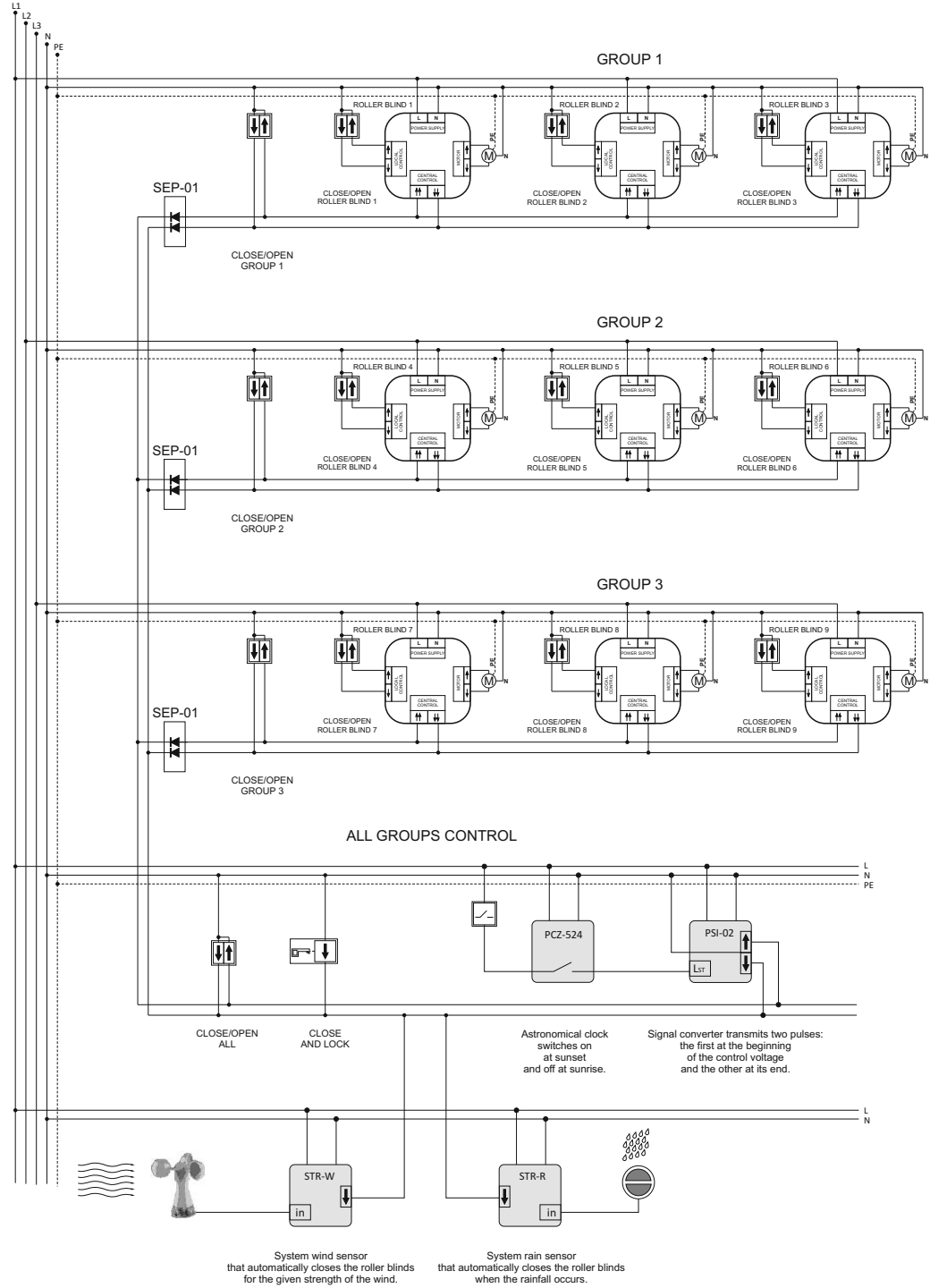

Example of extended control divided into additional groups of roller blinds