



F&F Filipowski sp. j.
Konstantynowska 79/81, 95-200 Pabianice, POLAND
phone/fax (+48 42) 215 23 83 / (+48 42) 227 09 71
www.fif.com.pl; e-mail: biuro@fif.com.pl

LE-03d CT200

Electric energy meter,
3-phase



Do not dispose of this device in the trash along with other waste!

According to the Law on Waste, electro coming from households free of charge and can give any amount to up to that end point of collection, as well as to store the occasion of the purchase of new equipment (in accordance with the principle of old-for-new, regardless of brand). Electro thrown in the trash or abandoned in nature, pose a threat to the environment and human health.



Purpose

The LE-03d CT200 is a static (electronic) calibrated electricity meter of three-phase alternating current in a semidirect system. The meter is designed to work with current transformers with a primary current of 200 A and a secondary current of 5 A. The maximum measured current of the system is determined by the value of the primary current of the current transformer used. When using transformers with dedicated parameters, the meter shows the actual value of electricity consumed by the system.

Functioning

A special electronic system under the influence of flowing current and applied voltage in each phase generates pulses proportional to the energy drawn in the respective phase. Energy consumption in the phase is indicated by a flashing of corresponding LED (L1, L2, L3). The sum of the three phase pulses is indicated by a flashing LED and converted into energy absorbed throughout the three-phase system. Its value is displayed by the segment LCD display.

Pulse output

The meter is equipped with pulse output open collector (OC type). This allows you to connect another pulse device (SO) that reads pulses generated by the meter.

No additional connected equipment is required for proper operation of the meter.

Sealing

The meter has sealable input and output terminal covers to prevent any attempts to bypass the meter.

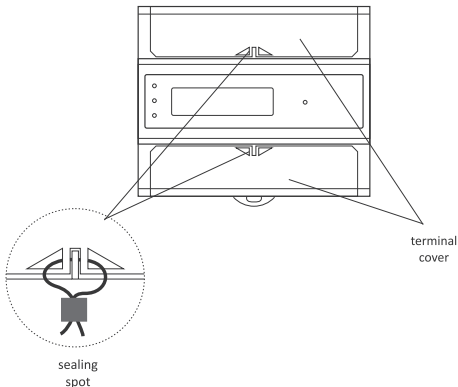

Meter number

The meter is marked with individual serial number allowing its unambiguous identification. The marking is laser engraved and cannot be removed).

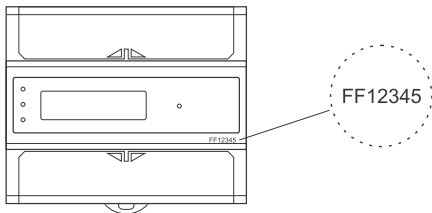

Front description

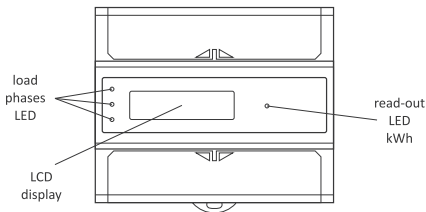

Dimensions

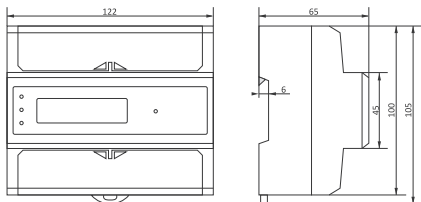

Mounting

1. Disconnect the power supply.
2. The indicator mounted on a rail in the distribution box.
3. Connect the voltages of controlled phases to the terminals in accordance with the markings 18 (L1), 17 (L2), 16 (L3).
4. Connect the transformers to the phase conductors and connect the secondary outputs to the terminals in accordance with the markings 1-2 (L1), 3-4 (L2), 5-6 (L3).
5. N-wire connect to terminal 15.
6. In order to increase the safety of the system and the measurement accuracy, it is recommended to ground the terminals (S2) of the secondary side of current transformers.
7. Additional pulse receiver connected (optional) to terminals 9 (+) i 8 (-).



Additional pulse receiver is not required

Wiring diagram

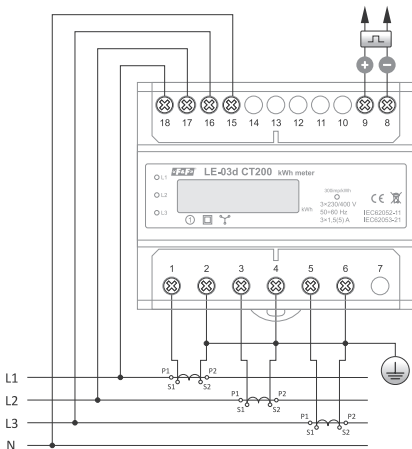

Current measurement circuits:

1-2 L1 phase

3-4 L2 phase

5-6 L3 phase

Pulse output (open collector):

8 transistor emitter (-)

9 transistor collector (+)

cont. on next page

The circuit for measuring the voltage and supply of the meter:

15	neutral N-wire
16	L3 phase
17	L2 phase
18	L1 phase

Technical data

installation	4-wire
rated voltage	3×230/400 V
minimum measured current	0.04 A
base current	3×1.5 A
maximum current	3×5 A
voltage measuring range	160÷265 V
transformer type	200/5 A
measurement accuracy (IEC62052-11, IEC62053-21)	1
rated frequency	50 Hz
insulation protection class	II
own power consumption	<10 VA; <2 W
indication range	0÷9999999 kWh
constant	300 pulses/kWh
current consumption signalling	3× red LED
read-out signalling	red LED
pulse output	
type	open collector
maximum voltage	27 V DC
maximum current	27 mA
pulse constant	300 pulses/kWh
pulse time	35 ms
working temperature	-25÷55°C
terminal	25 mm ² screw terminals

dimensions	7 modules (122 mm)
mounting	on TH-35 rail
ingress protection	IP20

Warranty

F&F products are covered by a 24-month warranty from the date of purchase. The warranty is only valid with proof of purchase. Contact your dealer or contact us directly.

CE declaration

F&F Filipowski sp. j. declares that the device is in conformity with the essential requirements of The Low Voltage Directive (LVD) 2014/35/EU and the Electromagnetic Compatibility (EMC) Directive 2014/30/UE.

The CE Declaration of Conformity, along with the references to the standards in relation to which conformity is declared, can be found www.fif.com.pl on the product subpage.

General work safety conditions

- » Please read the instructions carefully before installation.
- » The device should be installed and operated by qualified personnel who are familiar with its design, operation, and associated risks.
- » Do not install a meter that is damaged or incomplete.
- » The user is responsible for proper grounding of the system, proper selection, installation, and efficiency of other devices connected to the meter, including safety devices such as over-current, residual current and overvoltage circuit breakers.
- » Before connecting the power supply, make sure that all cables are connected correctly.
- » It is essential to observe the operating conditions of the meter (supply voltage, humidity, temperature).
- » To avoid electric shock or damage to the meter, turn off the power supply whenever the connection is changed.
- » Do not make any changes to the unit yourself. Doing so can result in damage to or improper operation of the device, which in turn can pose a threat to people operating it. In such cases, the manufacturer is not responsible for the resulting events and may refuse the provided warranty in the event of a complaint.