



F&F Filipowski L.P.
Konstantynowska 79/81, 95-200 Pabianice, POLAND
phone/fax (+48 42) 215 23 83 / (+48 42) 227 09 71
www.fif.com.pl; e-mail: biuro@fif.com.pl

AT-1I-DS

Temperature transducer
with current output



Do not dispose of this device in the trash along with other waste!

According to the Law on Waste, electro coming from households free of charge and can give any amount to up to that end point of collection, as well as to store the occasion of the purchase of new equipment (in accordance with the principle of old-for-new, regardless of brand). Electro thrown in the trash or abandoned in nature, pose a threat to the environment and human health.



Purpose

The AT-1I-DS temperature transducer has been designed for temperature measurement using the DS1820 series digital temperature sensor and converting measurement result into an analog current signal in the range of 4÷20 mA.

Features

- » Continuous measurement of ambient temperature using digital temperature sensors DS1820, DS18S20 and DS18B20 (sensor to be purchased separately);
- » Compatible with the RT4 temperature sensors (temperature range -30÷65°C) manufactured by F&F;
- » Adjustable measuring range;
- » Optical indication of the operation of the transducer and the state of the connected sensor.

Front description

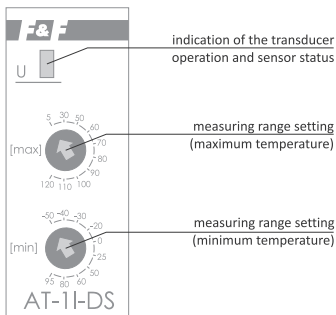

Mounting



Installation of the transducer should be performed by an installer with appropriate qualifications and experience in connecting electrical installations.



It is recommended to use high quality power supplies with a good output voltage filtering ratio to power the transducer.



Do not route signal cables, especially the cable for the temperature sensor, in parallel with other power cables.



It is recommended to use a 3-core shielded cable to connect the temperature sensor. The shield of the cable on one side must be connected to PE.



It is recommended to use a UTP twisted-pair cable to connect the power supply and the receiver. The maximum length of the UTP cable must not exceed 300 m.

1. Turn off the power to the switchboard.
 2. Mount the module on a DIN rail in the distribution box.
 3. Connect the power to terminal 1 and the receiver to terminal 3 according to the diagram.
-



To ensure the correct operation of the transducer, the value of the supply voltage should be adjusted to the resistance of the receiver and the line. Example maximum resistance values as a function of supply voltage are presented in the table below:

Power supply	Maximum resistance of the receiver
9 V	375 Ω
12 V	500 Ω
24 V	1000 Ω
30 V	1200 Ω

4. Connect the temperature sensor to terminals 10-12 according to the color markings of the RT4 sensor, or the pinout of the DS1820 sensor.
5. Use **MIN** and **MAX** potentiometers to set the required measuring range.



The set maximum temperature (**MAX**) must be higher than the minimum temperature (**MIN**). Failure to meet this condition will block the transducer and signal an error.

6. Switch on the power supply to the switchboard.

Wiring diagram

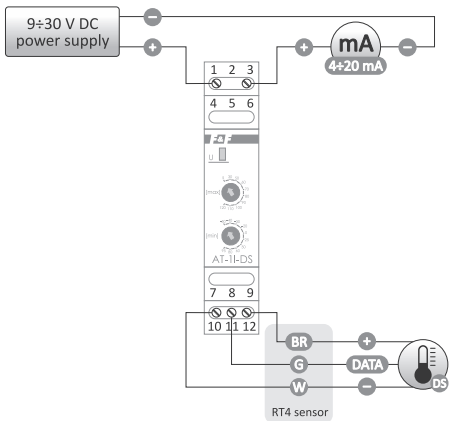

- 1 – power supply (+)
- 3 – current output 4÷20 mA
- 10 – temperature sensor [white] – power supply (-)
- 11 – temperature sensor [green] – data line (DATA)
- 12 – temperature sensor [brown] – power supply (+)

Transduction characteristics

The value of the output current depends on the current temperature and the set measuring range.

The shape of the characteristic is shown in the figure below:

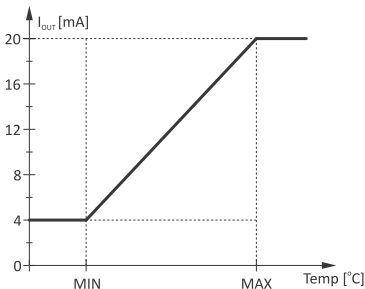

Incorrect configuration of the transducer or sensor failure is indicated by special output signal levels given in the table below:

Level	Description
20.3 mA	Short circuit at the sensor output
20.6 mA	No sensor connected
20.9 mA	Incorrect measuring range

LED signalling

The operation of the transducer is indicated by the LED signal light located on the front of the device.

Signal light	Description
ON	The transducer and sensor are working properly
Short blinks every 1 second	Incorrectly set measuring range
Rapid, frequent blinking	Sensor error (short circuit at the output or sensor not connected)

Technical data

power supply	9÷30 V DC
current	4÷20 mA
measurement range	-50÷125°C
temperature sensor	DS1820, DS18S20, DS18B20
transducer accuracy	1%
temperature sensor accuracy (typical)	
temperature -55÷-10°C	2°C
temperature -10÷85°C	0.5°C
temperature 85÷125°C	2°C
receiver maximum resistance	
supply 9 V	375 Ω
supply 12 V	500 Ω
supply 24 V	1000 Ω
supply 30 V	1200 Ω

cont. on next page

power consumption	≤0.6 W
working temperature	-25÷55°C
terminal	2.5 mm ² screw terminals
tightening torque	0.4 Nm
dimensions	1 module (18 mm)
mounting	on TH-35 rail
ingress protection	IP20

Warranty

The F&F products are covered by a warranty of the 24 months from the date of purchase. Effective only with proof of purchase. Contact your dealer or directly with us.

CE declaration

F&F Filipowski L.P. declares that the device is in conformity with the essential requirements of the Electromagnetic Compatibility (EMC) Directive 2014/30/UE.

The CE Declaration of Conformity, along with the references to the standards in relation to which conformity is declared, can be found at www.fif.com.pl on the product page.