



ul. Konstytucyjna 79/81  
95-200 Pabianice  
tel/fax 48 42 2270971 POLAND  
e-mail: fif@fif.com.pl

## STR-421 24V

### ROLLER BLIND CONTROLLER

#### double-button type



5 9 0 8 3 1 2 5 9 1 4 5 0

www.fif.com.pl

F&F products are covered by an 24 months warranty from date of purchase

#### PURPOSE

The roller blind controllers STR-421 are designed for controlling roller blinds (up and down movement) or other devices (for example, gates) that are driven by a single-phase AC electric motor and operated by means of momentary switches (for example, bell-pushes). The controller can operate as an independent unit (designated for opening/closing one roller blind) as well as the controllers can be combined into groups that enable the central controlling of many roller blinds

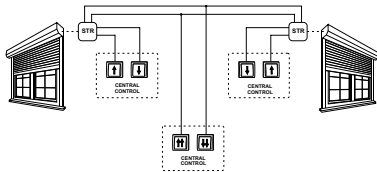

#### WIRING DIAGRAM

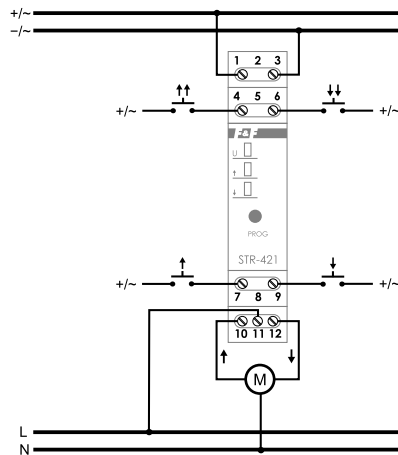

Description of connection:

- 1 - 3 supply 24V AC/DC
- 4 central control - to direction „UPWARDS” ↑↑
- 6 central control - to direction „DOWNWARDS” ↓↓
- 7 central control - to direction „UPWARDS” ↑
- 9 central control - to direction „DOWNWARDS” ↓
- 10 supply of motor - output in to direction „UPWARDS” ↑
- 11 supply of motor 230V (L)
- 12 supply of motor - output in to direction „DOWNWARDS” ↓

#### FUNCTIONING

Supplied the relay is to signal by shine of green LED U. The roller blind motor is activated by the momentary switching of a current pulse (L or N) to one of the control inputs. The motor is activated at a time programmed previously by the user. The activation of motor is to signal by shine of red LED ↑ or ↓. Also, there is a possibility of stopping the rolled blind activated at a level selected by the user (non-complete opening or closing of the roller blind).

Control inputs of relay:

**Local control** - a group of push-buttons connected to joints 7 and 9 that controls one roller blind.

↑ - upwards (opening); ↓ - downwards (closing).

Pressing the local control push-button activates the movement of the roller blind in a selected direction. If the roller blind is already moving, pressing the local control push-button will stop the roller blind.

**Central control** - a common group of push-buttons for many controllers (minimum two controllers) that controls all roller blinds included in the central control system and connected to joints 4 and 6.

↑↑ - all upwards; ↓↓ - all downwards.

Pressing the central control push-button activates the movement of the roller blinds in a selected direction. If one of the roller blinds is already moving in the same direction, its movement will be continued. If one of the roller blinds is moving in the opposite direction, this roller blind will be first stopped and then its movement will be activated in the direction in accordance with the command sent to the central input.

**ATTENTION!** The central control enables only activating the movement of the roller blinds in a selected direction. The roller blind will be stopped after the programmed movement time or when any of the local control push-buttons is pressed.

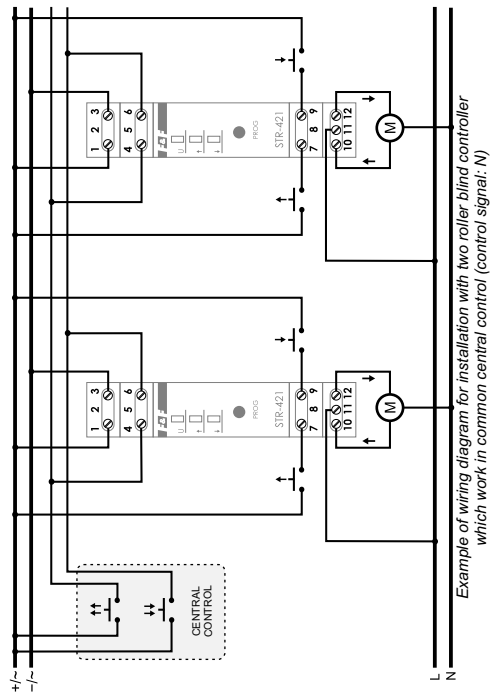

Example of wiring diagram for installation with two roller blind controller which work in common central control (control signal: N)

### Programming time of enclose

1. Press and hold a button PROG for time when green LED U start to pulsate.
2. When we again press a button PROG (START). Controller start count a time which is to signal by pulsate of green LED.
3. Press again a button PROG (STOP). Controller remember a counted time. Programmin mode is automaticly closed ( green LED U shine continually).



\* If at time 30 sec from activate programming mode a count of time doesn't to start, then controller will out from programming mode.  
\* Max time for programming 10min. Test by long time than 10 min to cause controller automaticly out from programming mode.  
\* Input to programming mode possible is only when motor of roller is OFF.  
\* In programming mode a controller doesn't to react for outward control signal.

### ASSEMBLY

1. Take OFF the power.
2. Put on the controller on the rail in the switchgear box.



Do not install to device which is broken or incomplete.

3. Connect power cable to joint 1-3 with marks.



Group of controllers which working with common central control should be supplied from the same phase e.g only L1.

### TECHNICAL DATA

|                               |                                    |
|-------------------------------|------------------------------------|
| supply                        | 24V AC/DC                          |
| current load AC-3             | <2A                                |
| control pulse current for L/N | <1mA                               |
| power supply indicator        | LED green                          |
| power supply indicator        | 2×LED red                          |
| power consumption             | 0,8W                               |
| working temperature           | -25+50°C                           |
| connection                    | screw terminals 2,5mm <sup>2</sup> |
| dimensions                    | 1 module (18mm)                    |
| fixing                        | on rail TH-35                      |



During assembly of controller should be take special care  
Wrong connection could cause to give a shock and/or break controller or connected device.

4. Choose control option (control impulse +/- lor -/-). Switch of local control and central control connect with marks with function to joint to choosen cable (for supply from DC to cable +, for supply from AC to one common cable ~).



All control inputs of controllers which works separately or in group should have to common control impulse option - all are controlling from the same device (e.g. transformer).



Choosing control option from DC to control inputs should be put impulse + from the same device ( e.g. transformer)



Connection different device of supply to inputs of control inputs of controller can cause to wrong work of system and break controllers.

5. Controlled roller motor connect properly to joints 10 and 12 and to N. To joint 11 connect to supply (L) of motor.
6. Take ON the power.
7. Programm time of upwards/downwards of roller. Prescribed is that programmed time should be longer than 10 sec from real time of upwards/downwards.