

**ELECTRICITY CONSUMPTION METER**  
 three-phase

**LE-03**

**WARRANTY.** The F&F products are covered by a warranty of the 24 months from the date of purchase. Effective only with proof of purchase. Contact your dealer or directly with us. More information how to make a complaint can be found on the website: [www.fif.com.pl/reklamacja](http://www.fif.com.pl/reklamacja)



**CE** Do not dispose of this device in the trash along with other waste! According to the Law on Waste, electro coming from households free of charge and can give any amount to up to that end point of collection, as well as to store the occasion of the purchase of new equipment (in accordance with the principle of old-for-new, regardless of brand). Electro thrown in the trash or abandoned in nature, pose a threat to the environment and human health.

**Purpose**

LE-03 is a static (electronic) calibrated electricity meter of three-phase alternating current in a direct system.

**Functioning**

A special electronic system under the influence of flowing current and applied voltage in each phase generates pulses proportional to the energy drawn in the respective phase. Energy consumption in the phase is indicated by a flashing of corresponding LED (A, B, C). The sum of the three phase pulses is indicated by a flashing LED and converted into energy absorbed throughout the three-phase system. Its value is displayed by the segment LCD display. The fractional digit represent the decimal (.1 kWh = 100Wh).

- 1 -

**Meter front description**

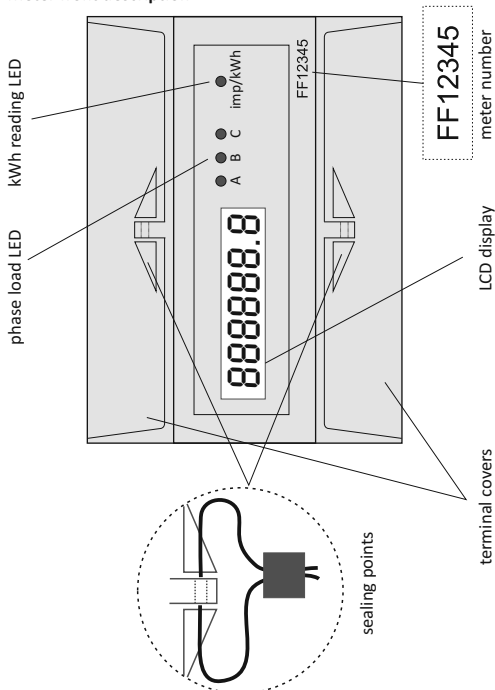

- 3 -

**Pulse output**

The meter is equipped with pulse output SO+ - SO-. This allows you to connect another pulse device (SO) that reads pulses generated by the meter. No additional connected equipment is required for proper operation of the meter.

Length of the SO+ SO- pulses depends on the load of the meter:

5÷40A	80 msec	75A	46 msec
45A	75 msec	80A	42 msec
50A	68 msec	85A	40 msec
55A	62 msec	90A	38 msec
60A	57 msec	95A	36 msec
65A	52 msec	100A	34 msec
70A	48 msec		

**Sealing**

The meter has sealable input and output terminal covers to prevent any attempts to bypass the meter.

**Meter number**

The meter is marked with individual serial number allowing its unambiguous identification. The marking is laser engraved and cannot be removed.

- 2 -

**Dimensions**

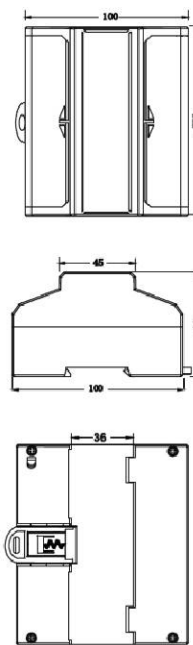

- 4 -

### Technical data

reference voltage	3×230/400V+N
base current	10A
maximum current	100A
minimum current	0.04A
accuracy class	1 <sup>st</sup> class
compliance	IEC61036
own power consumption	<10VA; <2W
indication range	0÷999999.9kWh
meter constant	(1.25 Wh/pulse) 800pulses/kWh
current consumption signalling L1, L2, L3 phases	3× red LED
kWh read-out signalling	red LED
SO+ SO- pulse output	open collector
SO+ SO- connection voltage	<30V DC
SO+ SO- connection current	<27mA
SO+ SO- constant	(1.25 Wh/pulse) 800pulses/kWh
SO+ SO- pulse duration (load-dependent)	34÷80msec
SO+ SO- wire length	<20m
working temperature	-20÷55°C
terminal	25mm <sup>2</sup> screw terminals
housing	ABS material
dimensions	7 modules (122×100×65mm)
mounting	on TH-35 rail
ingress protection	IP20

- 5-

### Connection diagram

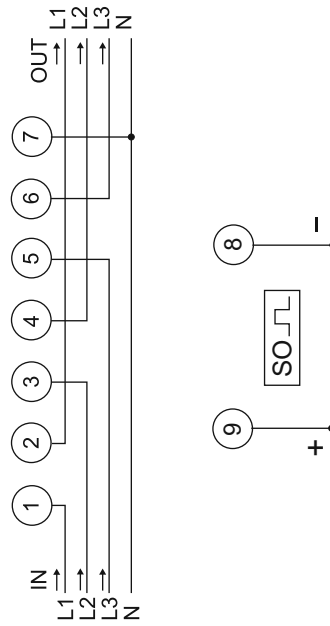

- 6-

### Installation

1. Disconnect the switching station power.
2. Mount the meter on the TH rail in the distribution box.
3. Open the covers on the terminals.
4. Connect the power to terminal 1 (L1 IN), terminal 3 (L2 IN), terminal 5 (L3 IN).
5. Connect a measured circuit or a single receiver to terminal 2 (L1 OUT), terminal 4 (L2 OUT), terminal 6 (L3 OUT).
6. Connect wire N to terminal 7.
7. Optionally connect the RS-485 network wires to the 9(A+) - 8(B-) terminals.
8. Close the covers on the terminals and optionally seal them.

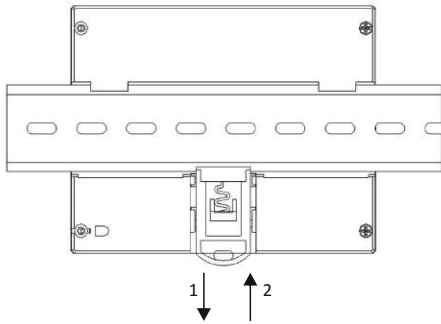

- 7-

### General safety conditions

- \* Please read the manual carefully prior to installing the meter.
- \* The meter should be installed and operated by qualified personnel familiar with the construction, operation and any hazards involved.
- \* Do not install the meter if it is damaged or incomplete.
- \* The user is responsible for proper grounding, selection, installation and functionality of any other devices connected to the meter, including security devices such as overcurrent protection breakers, differential switches and surge protectors.
- \* Before connecting the power supply make sure that all cables are connected properly.
- \* Always follow the operational conditions of the meter (voltage, humidity, temperature).
- \* In order to avoid electric shock or damage to the meter, disconnect the power before each change in connection configuration.
- \* Do not modify the device on your own, as this may cause damage or improper operation of the meter and consequently expose the users to risk. In these cases the manufacturer is not liable for ensuing events and reserves the right to refuse the warranty claims on the counter.



D170828

- 8-