

## DATA SHEET



### mH-R8x8

Eight-fold actuator relay  
of the F&Home system

The logo consists of a red house-shaped icon above the text 'F&Home' in a grey sans-serif font.

Relay module mH-R8x8 is an actuator module designed for direct connection to control modules mH-IO32, mH-E16 and mH-IO12E6. The module is equipped with eight independently controlled NO (normally open) outputs with a maximum load capacity of 8 A. The module is mounted in the switchgear where it occupies a field of 6 modules and is supplied with 24 V DC voltage. The contact is closed by providing a - 24 V signal to the corresponding input (control with the negative terminal of a power supply).

**WARNING**

The mH-R8x8 module is an old version produced since 2012. Its successor, mH-R8x8.2, is currently on sale.

**Inputs / outputs**

The mH-R8x8/2 module has eight inputs controlled by the negative terminal of the power supply. The module is adapted to operate as an actuator module for logical modules of the following types: mH-IO32, mH-IO12E6, mH-E16. The module outputs are relay contacts operating in the NO (normally open - supplying a signal to one of the inputs activates the given relay) mode.

**Power supply**

The mH-R8x8 module is supplied with 24 V DC voltage. Power supply polarity and common potential with logic modules are important - the same power supply or power supplies with the connected ground.

**Operating principle**

Providing a control signal of -24 V at one of the inputs activates the relay assigned to this input.

**Notes**

- Inputs of the module are located at the top and outputs at the bottom.
- Pay special attention to the polarity of the module supply voltage.
- In case of the need to switch on large currents, use the larger relays mH-R2x16 or additional contactors.

Connection diagram

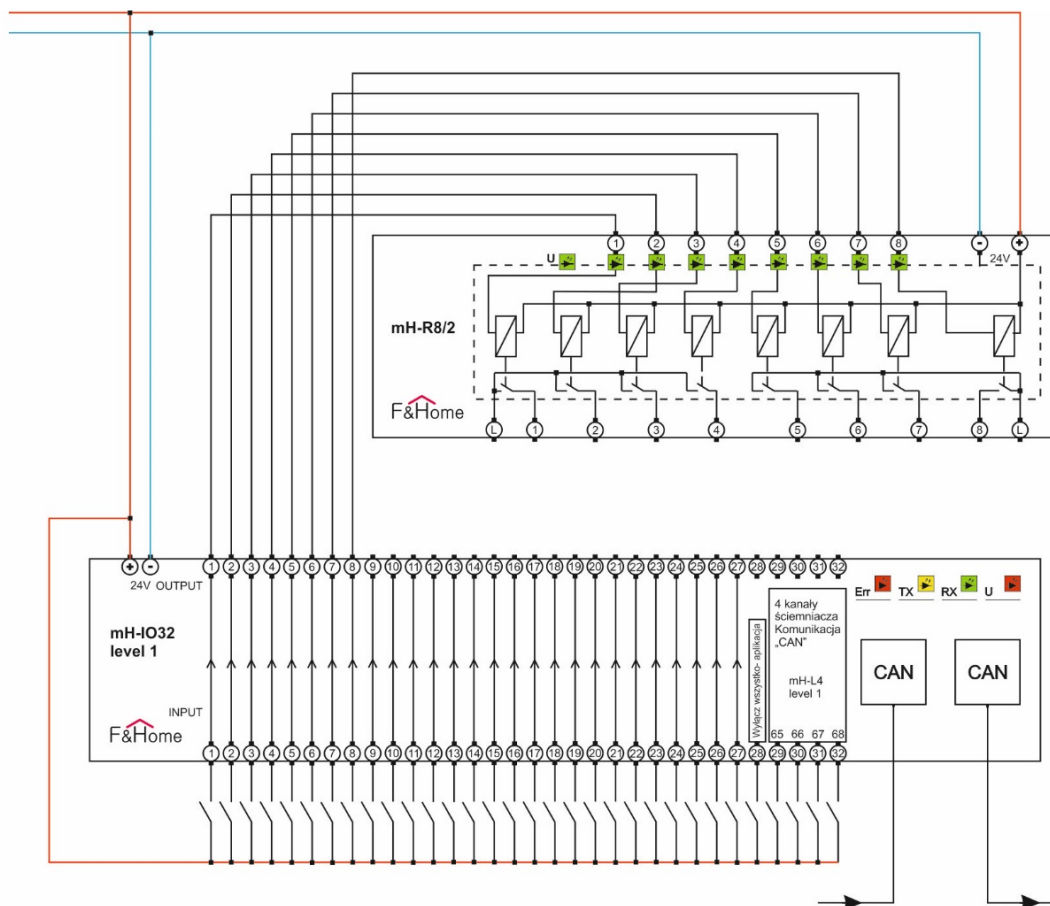
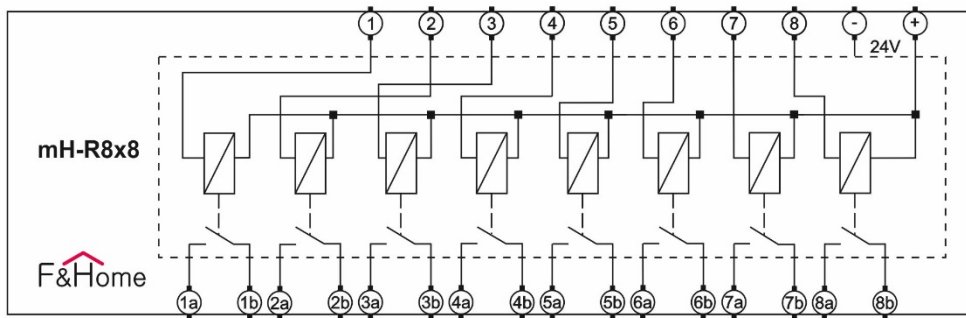

Connecting the actuator module (relays - mH-R8x8) to the input-output module.



The load value of the contact described on the unit refers to resistance receivers. For this type of non-inductive receivers, the power factor parameter is 1 (cosφ=1). Switching on inductive or capacitive loads (such as motors, impulse power supplies, etc.) leads to a significant shortening of the life of the contacts. For example, load for which cosφ=0.5 shortens the service life (number of switching cycles) by 20%, and for cosφ=0.25 even by 50%. Depending on the nature of the connected receiver, the contact can be loaded with the following values:

LIGHT

SOURCES

STYK	ŻARÓWKI	HALOGENY	LED	ŚWIETŁÓWKI ENERGOOSZCZ. ELS	JARZENIÓWKI	JARZENIÓWKI Z KOMPENSACJĄ RÓWNOLEGŁĄ
6A	750W	500W	100W	150W	350W	250W
8A	1000W	600W	120W	250W	500W	350W
10A	1250W	900W	150W	300W	600W	400W
16A	2000W	1250W	250W	500W	1000W	750W
30A	3500W	2500W	400W	900W	1800W	1200W

- Styk - Contact
- Żarówki - Light bulbs
- Halogeny - Halogen lights
- LED - LED
- Świetlówki energooszczędne ELS - ELS energy-saving fluorescent tubes
- Jarzeniówki - Fluorescent tubes

Jarzeniówki z kompensacją równoległą - Fluorescent tubes with parallel compensation

STYK	PRĄD ZMIENNY			PRĄD STAŁY
	AC-1	AC-3	AC-15	DC-1 24V / 115V / 230V
	obciążenie bezindukcyjne lub obciążenie rezystancyjne (np. grzejnik)	wirujące urządzenia indukcyjne (np. silniki elektryczne)	zmiennie obciążenia elektromagnetyczne (np. cewki styczników)	obciążenie bezindukcyjne lub obciążenie rezystancyjne (np. żarówki)
6A	1500VA	0.185kW	300VA	6 / 0.2 / 0.12 A
8A	2000VA	0.25kW	350VA	8 / 0.3 / 0.15 A
10A	2500VA	0.37kW	500VA	10 / 0.4 / 0.2 A
16A	4000VA	0.5kW	750VA	16 / 0.5 / 0.25 A
30A	7200VA	1.0kW	1200VA	20 / 0.7 / 0.35A

THE NATURE OF THE LOAD OF

THE RECEIVERS

Prąd zmienny - Alternating current

Prąd stały - Direct current

obciążenie bezindukcyjne lub obciążenie rezystancyjn (np. grzejnik) - non-inductive load or resistive load (such as radiator)

wirujące urządzenia indukcyjne (np. silniki elektryczne) - rotating inductive devices (such as electric motors)

zmiennie obciążeni elektromagnetyczne (np. cewki styczników) - variable electromagnetic loads (such as contactor coils)

**obciążenie bezindukcyjne lub obciążenie rezystancyjne (np. żarówki)** - non-inductive load or resistive load (such as light bulbs)

The above data is indicative only and will depend to a large extent on the design of a specific receiver (especially LED lamps, ESL energy-saving lamps, electronic transformers and pulse power supplies), switching frequency and operating conditions.

When selecting the maximum load for a given type of relay, take into account:

<p><b>Incandescent light bulbs</b></p>	<p>Cold bulb resistance is usually at least 10-12 times lower than the resistance of a working bulb. For example, a 230 V/100 W cold bulb has a resistance of approx. 40 ohm, which means that in the most unfavorable case, a current of approx. 5.5 A flows through it at the moment of switching on for at least a few milliseconds, which decreases to the rated value of approx. 0.4 A after the bulb heats up.</p>
<p><b>Halogen lamps</b></p>	<p>As in the case of an ordinary bulb, the resistance of a colder halogen bulb is 16-20 times lower than the resistance of a working bulb. This means that for a 230 V/100 W bulb, a current of 6.5-8 A can flow when the bulb is switched on.</p>
<p><b>Single-phase induction motor (such as a pump)</b></p>	<p>The starting current of the motor can be up to 5-10 times the rated current. In addition, such motors are equipped with additional starting capacitors which can further increase the value of the starting current.</p>
<p><b>Pulse power supply (for example for LED lighting)</b></p>	<p>An increasing number of electrical devices, including LED bulbs, energy-saving bulbs and fluorescent lamp controllers are being equipped with pulse power supplies. At the same time, it is the worst possible type of load. This results from the fact that at the input of such power supplies there are capacitors, which at the moment of switching on of the power supply practically constitute a short circuit - currents of values 100-200 times higher than the rated currents of such a power supply may flow there for a few milliseconds.</p>

Technical data table

Module type	actuator - 8 channels
Rated supply voltage	24 V DC
Power supply voltage tolerance	-20%, +10%
Maximum load of a single channel	According to the table on the previous page
Current of a single channel (load-dependent)	8 A (AC-1)
Storage temperature	-20°C to +50°C
Operating temperature	0°C, +40°C
Humidity	<=85% (without condensation or aggressive gases)
Dimensions	105 x 65 x 90 mm (6 modules)
Dimensions of the packaging	119 x 104 x 75 mm
Ingress protection	IP20
Operating position	any
Enclosure type	for DIN rail
Net weight	225 g
Gross weight (including packaging)	270 g

**WARNING**

The method of connection is specified in this manual. Installation, connection and adjustment should be carried out by authorized electricians who are familiar with the operating instructions and the functions of the module.

The correct operation is affected by the way the module is transported, stored and used. Installation of the module is not recommended in the following cases: missing components, damage to the module or its deformation.

In case of malfunction, please contact the manufacturer.